

SHB600X

smeg 60cm wallmount rangehood



EAN	9345025000828
finish	stainless steel
dimensions	598mmW x 420mmD x 890mmH
installation	wallmount
motor	1 x 250W
air extraction	<ul style="list-style-type: none"> • duct direct to atmosphere — 150mm diameter ducting required • recirculate to kitchen — 125mm ducting required
capacity	710m ³ /hr (IEC 61591: p=0) 675m ³ /hr (IEC 61591: p=1)
noise rating	43–65 dBA (IEC 607048)
illumination	2 X 20w halogen globes
speeds	3 + intensive*, progressive button
maximum current	0.17 amps
power supply	220–240V, 50Hz
supplied	1 x mesh grease filter
optional	charcoal filter, part # KITFC161
weight	23.4kg gross, 16.9kg net
package dimensions	615x995x540mm

p = 0 → airflow direct out of motor housing
p = 1 → airflow after 1m & 90° bend + 1m

***INTENSIVE:** the Intensive Speed function activates maximum air extraction for 10 minutes to meet the needs heavy-duty cooking, such as stir-fry.

SHB600X

smeg 60cm wallmount rangehood

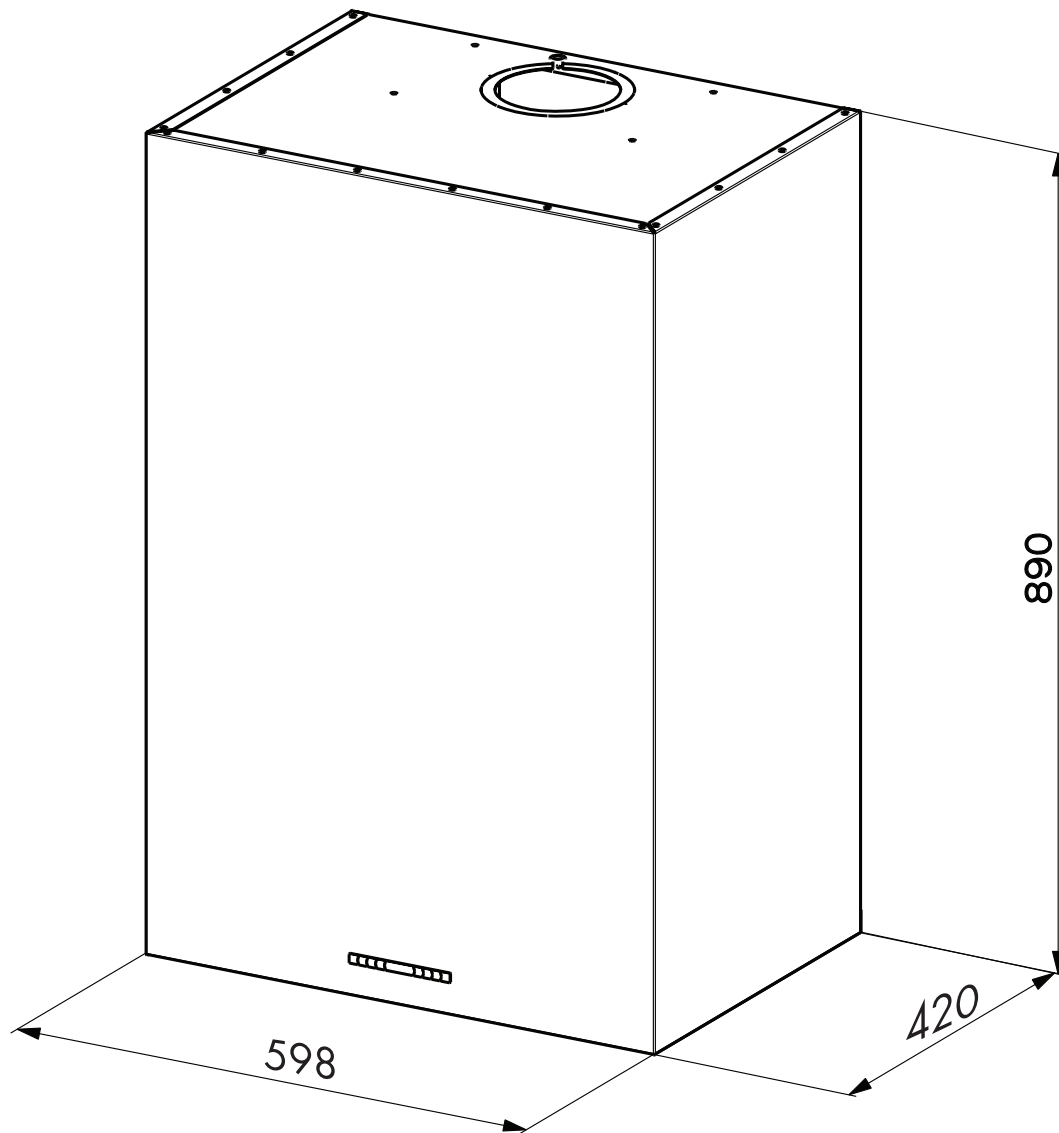

PLEASE NOTE: drawings are not to scale. They are to assist only.