

SFP4390XPZ 60CM CLASSIC COMPACT PYROLYTIC PIZZA OVEN



THERMOSEAL

The seal of Smeg's quality, technical excellence and taste: succulent roasts, crisp pastry and impressive baking is achieved in Smeg's unique, perfectly controlled cooking environment. Thermoseal maintains the perfect atmospheric balance in the cavity for optimum cooking conditions.

PYROLYTIC CLEANING

Smeg's pyrolytic cycle locks the door and heats the oven to around 500°C. This process carbonises any food residue or burnt-on grease to a small amount of ash, which can be simply wiped away with a damp cloth. Smeg also has Eco Pyro - the low energy option.

COOL DOOR TECHNOLOGY

Smeg's Cool Door system is a combination of technologies which is driven by a 22 blade tangential fan and includes a heat exchange baffle system. It draws cool air up through the panes of heat-reflective glass in the door, making it safe to the touch even when the oven is at pyrolytic temperatures of around 500°C.

EAN 8017709215347

Dimensions	597mmW x 456mmH x 571mmD
Finish	Fingerprint proof stainless steel Eclipse high visibility black glass
Total functions	16 + 20 SmartSense auto menus
Display	Large LCD
Capacity	50L
Cooking levels	3
Thermostat	30 - 250°C
Installation	Built-in
Programmability	Fully programmable
Cleaning	Pyrolytic, ECO Pyrolytic
Lighting	2 x 40W halogen
Supplied accessories	1 x Chrome Shelf 1 x chrome grill insert 1 x 40mm deep enameled baking tray 1 x Total telescopic guides 1 x Refractory stone 1 x base element cover 1 x pizza paddle
Optional accessories	PALPZ - Single-handle pizza paddle 38508/510 - Baking Dish GT1P-2 - Partial telescopic guides GT1T-2 - Total telescopic guides
Safety	Cool Door technology Thermal protection system Child safety lock Controls lock
Power	220-240V, 50/60Hz 3100W 1.5A Connection
Warranty	Two years parts and labour

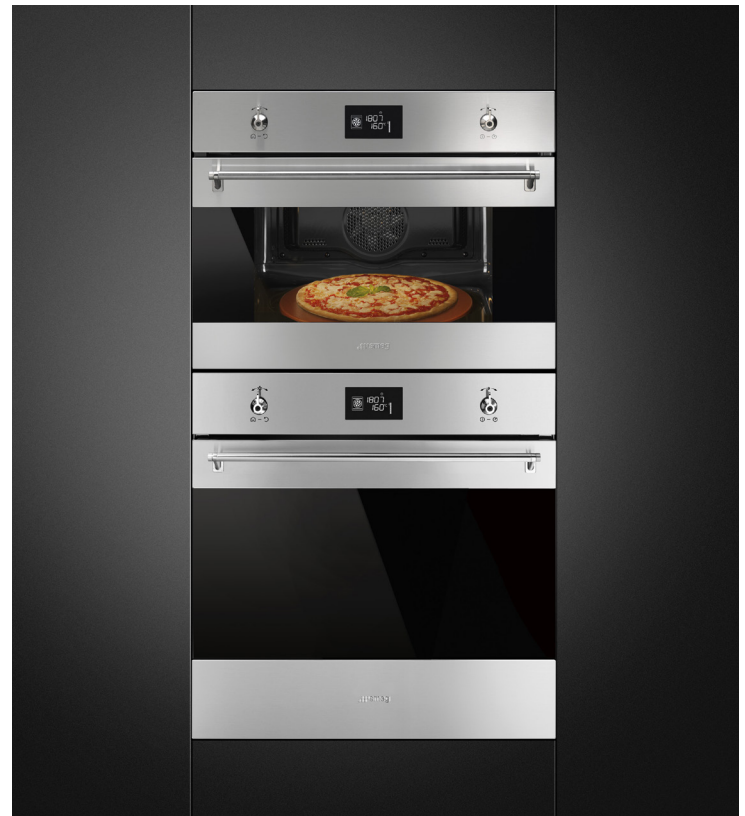

ID181010

COMPACT OVENS

SFP4390XPZ 60CM CLASSIC COMPACT PYROLYTIC PIZZA OVEN

Functions

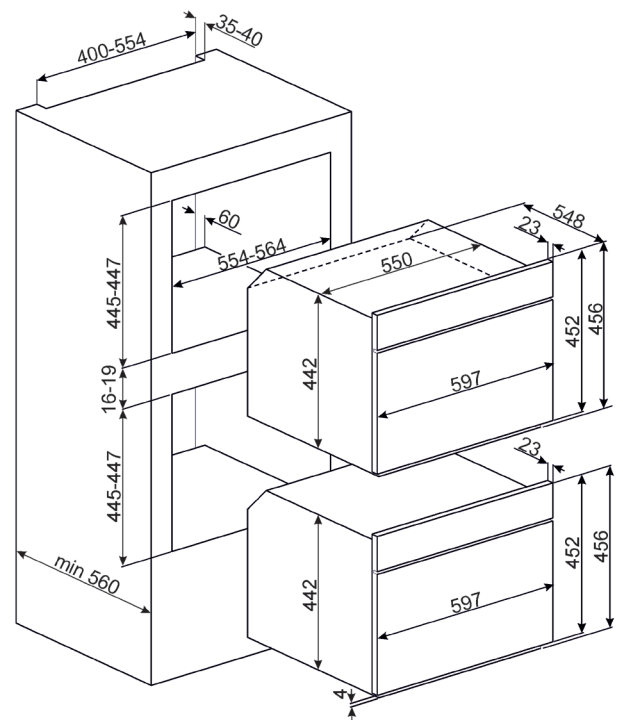
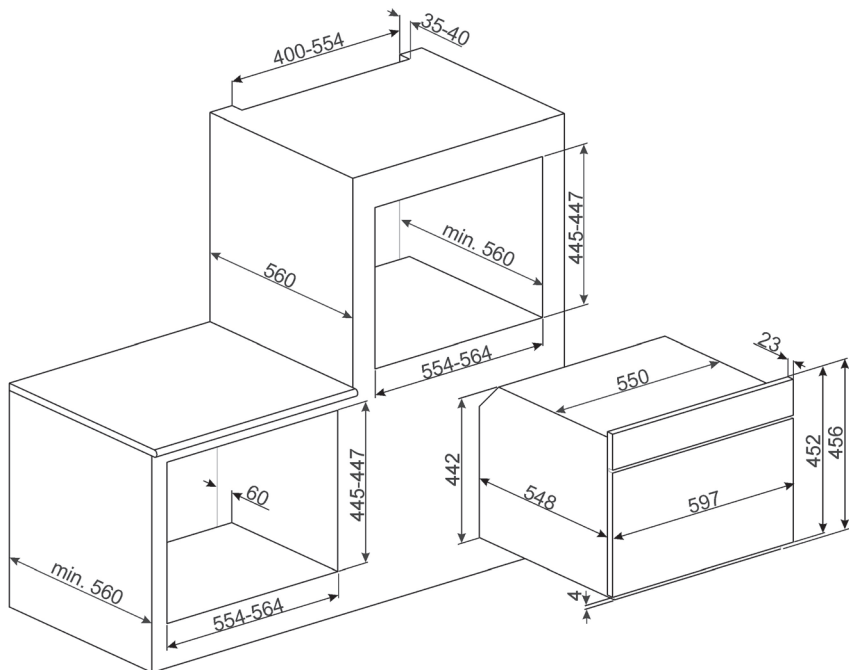
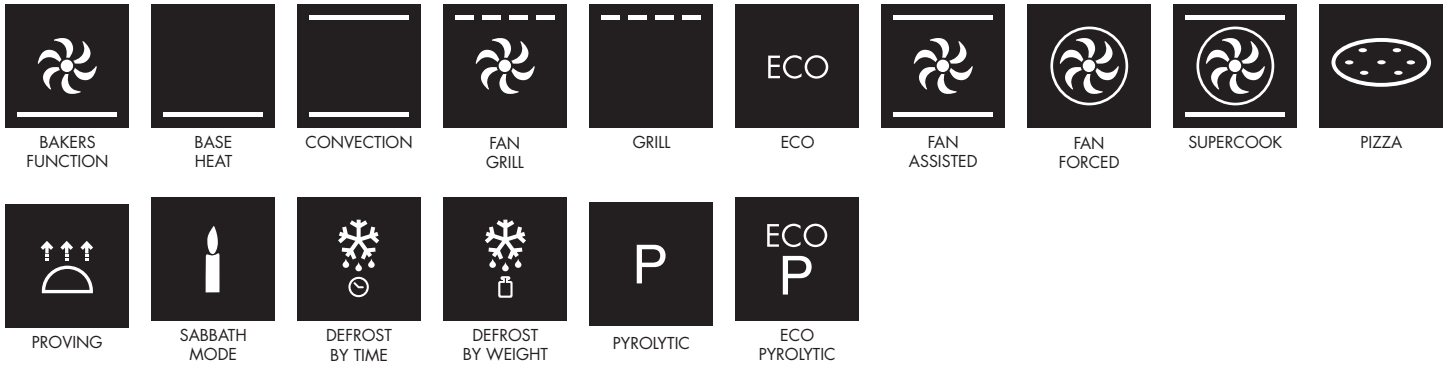

PLEASE NOTE: drawings are not to scale. They are to assist only.
 WARNING: technical specifications and product sizes can be varied by the manufacturer without notice.
 Cutouts for appliances should only be by physical product measurements. The above information is indicative only.