

SFA562X2

60CM THERMOSEAL OVEN



THERMOSEAL

The seal of Smeg's quality, technical excellence and taste: succulent roasts, crisp pastry and impressive baking is achieved in Smeg's unique, perfectly controlled cooking environment. Thermoseal maintains the perfect atmospheric balance in the cavity for optimum cooking conditions.

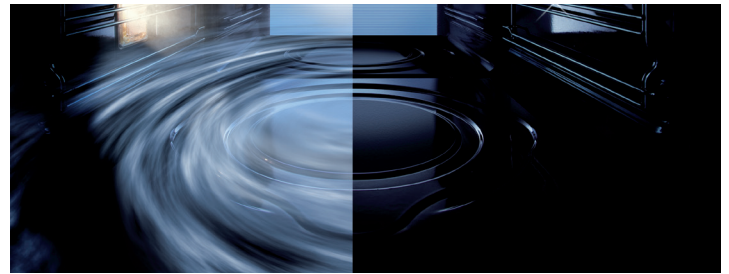

VAPOUR CLEAN

Smeg's Ever Clean enamel's tough surface has a glassy finish, so a simple spray of water and detergent around the cavity in conjunction with the Vapour Clean option will generate heat and steam to soften any grease for a wipe-clean result.



EVER CLEAN ENAMEL

The superior quality of Smeg's patented Ever Clean enamel, which is highly durable and easy to clean, is the result of nearly 70 years of enameling expertise; ensuring long-life performance of every Smeg oven.



COOL DOOR TECHNOLOGY

Smeg's Cool Door system is a combination of technologies which is driven by a 22 blade tangential fan and includes a heat exchange baffle system. It draws cool air up through the panes of heat-reflective glass in the door, making it safe to the touch even when the oven is at pyrolytic temperatures of around 500°C.

EAN 8017709250607

Dimensions	597mmW x 570mmD x 592mmH
Finish	Fingerprint proof stainless steel Eclipse high visibility black glass
Total functions	9
Display	Text on panel
Capacity	79L
Cooking levels	5
Thermostat	30 - 250°C
Installation	Flush, underbench or wallmount
Programmability	Countdown Timer
Cleaning	Vapour Clean
Lighting	1 x 40W halogen
Supplied accessories	1 x Chrome grill insert 1 x 40mm baking tray 2 x chrome shelves
Optional accessories	PRTX - Pizza stone PPR2 - Gourmet Cooking Stone PALPZ - Single-handle pizza paddle 38508/510 - Baking Dish GT1P-2 - Partial telescopic guides GT1P-2 - Total telescopic guides
Safety	Cool door technology, thermal protection system
Power	220-240V, 50/60Hz 3000W 1.5A Connection
Warranty	Two years parts and labour

SFA562X2
60CM THERMOSEAL OVEN

FUNCTIONS:

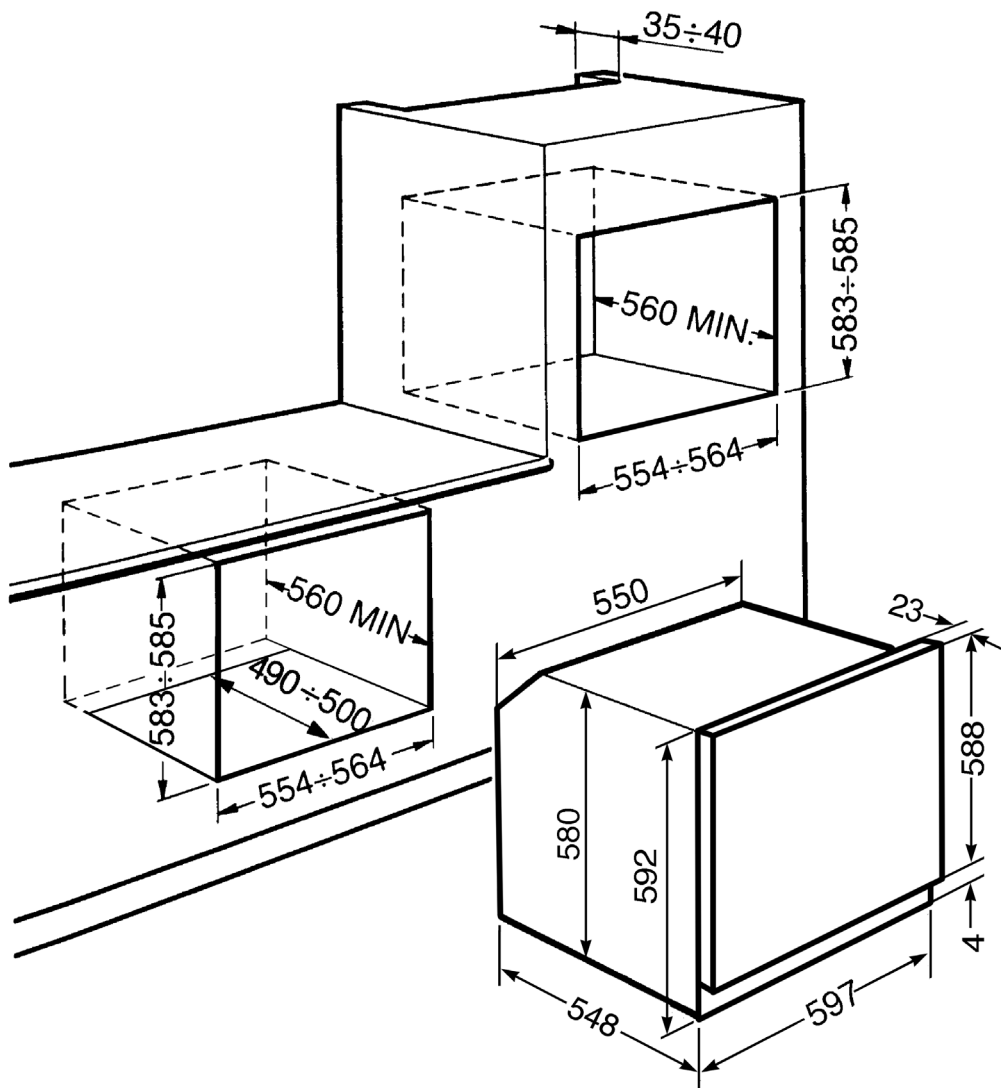
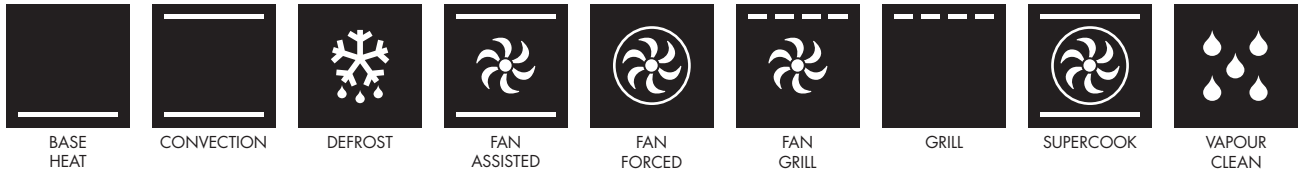

PLEASE NOTE: drawings are not to scale. They are to assist only.
 WARNING: technical specifications and product sizes can be varied by the manufacturer without notice.
 Cutouts for appliances should only be by physical product measurements. The above information is indicative only.

ID180109