

KMN75XA

smeg 75cm wallmount rangehood, stainless steel



EAN	9345025000873
finish	stainless steel/stainless steel fascia
dimensions	750mmW x 675mmH (body) 530-990mmH (flue) 370mmD
installation	wallmount
motor	1 x 340W centrifugal
air extraction	<ul style="list-style-type: none"> • duct direct to atmosphere — 150mm diameter ducting required • recirculate to kitchen — 125mm ducting required
capacity	930m ³ /hr (IEC 61591: p=0) 880m ³ /hr (IEC 61591: p=1)
noise rating	47-68 dBA
illumination	2 X 20w halogen globes
speeds	three, electronic touch control + intensive*
power	220-240V, 50Hz
filter prompt	30-hour stainless steel filter cleaning prompt 120-hour charcoal filter replacement prompt
supplied	2 x aluminium grease filters
optional	charcoal filters, part #KITFC152
weight	40.16kg gross, 29.42kg net

p = 0 → airflow direct out of motor housing
p = 1 → airflow after 1m & 90° bend + 1m

***INTENSIVE:** the Intensive Speed function activates maximum air extraction for 10 minutes to meet the needs heavy-duty cooking, such as stir-fry.

KMN75XA

smeg 75cm wallmount rangehood, stainless steel

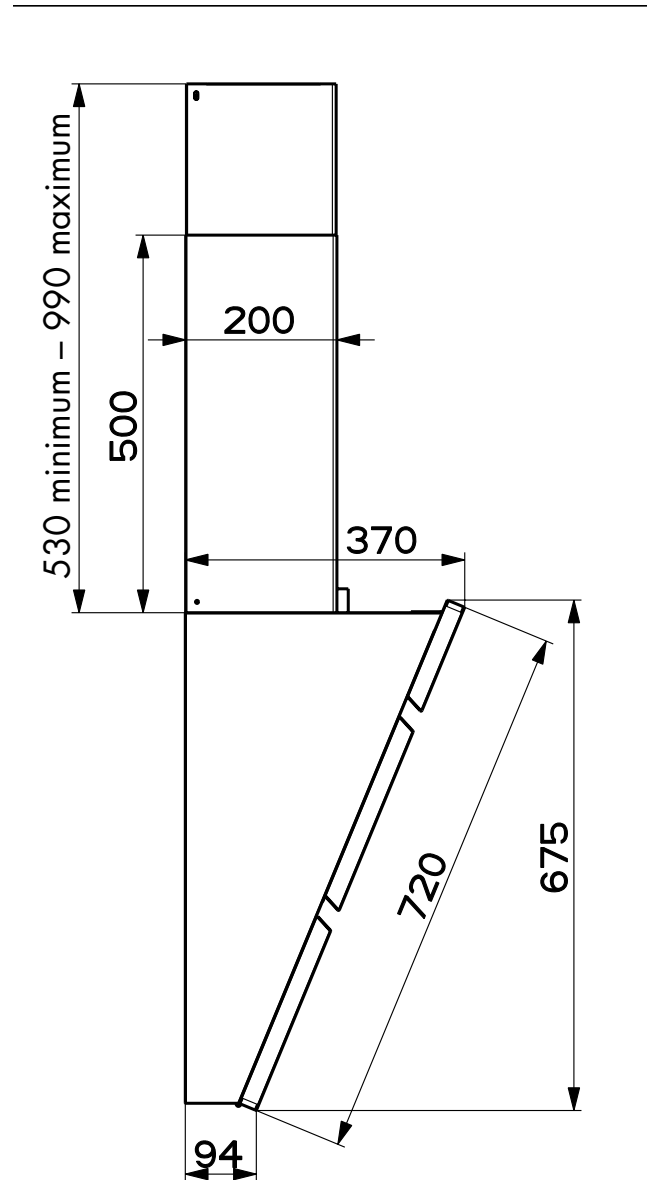
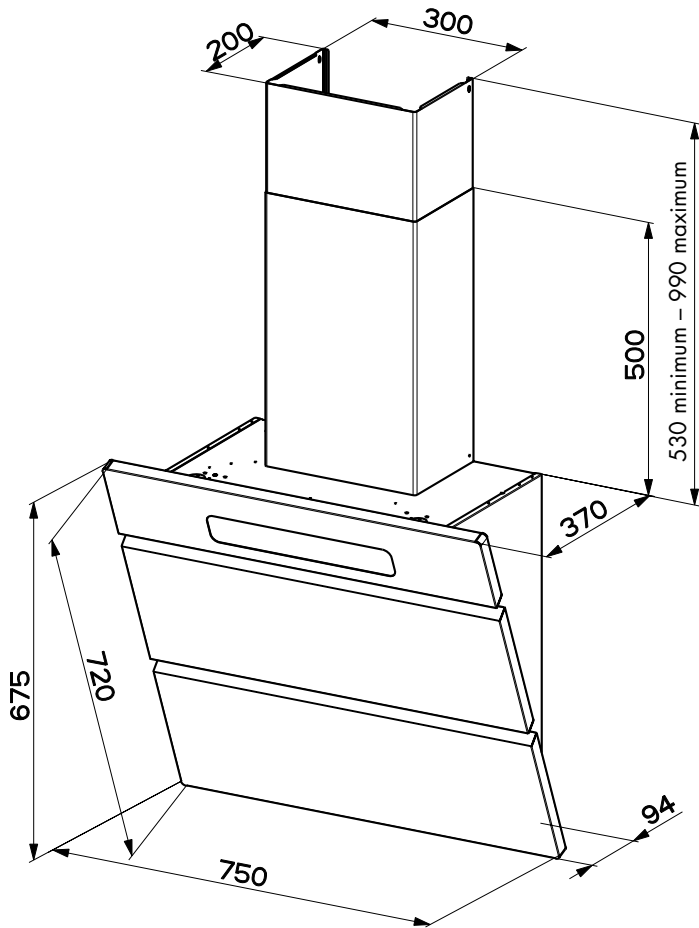

PLEASE NOTE: drawings are not to scale. They are to assist only.