

HOBD682D1 INTEGRATED INDUCTION COOKTOP



AUTOMATIC EXTRACTION FUNCTION

The design of the new HOBD hob is minimalism in its purest form. A unique piece of technology with a powerful integrated extractor fan, capable of instantly removing odours. The automatic extraction function allows the rangehood to automatically change speed in accordance with power level - selecting the most appropriate extraction level for a variety of cooking styles.

AQUAPROOF ENGINE & TWO LIQUID COLLECTORS

With HOBD, even little accidents during cooking pose no problem, thanks to the AquaProof Engine and two liquid collectors safety system. This comprises a small tank inside the extractor itself, which is useful if water or other liquids overflow during cooking. Simple to clean, the design keeps the most delicate parts of the appliance protected, ensuring continued functionality.

FLUSH CAST IRON GRILL

A cast iron grill lies at the centre of the HOBD hob, protecting the powerful integrated extractor fan. With no difference in the height across its surface, the glass ceramic cooktop is completely flush, so pans can be moved across it without encountering any obstacles. A few centimetres under the surface, the extraction motor instantly removes cooking odours and vapours much faster than a traditional hood.

POWER BOOST IN EACH ZONE

Smeg's HOBD induction cooktop features the power boost function in each zone. Boost provides temporary additional power to zones when an even more intense heat is required and is ideal for heating large quantities of water rapidly.

EAN 8017709298685

HOB

| | |
|--------------|--|
| Dimensions | 830mmW x 210mmH x 520mmD |
| Finish | Black ceramic |
| Installation | Topmount |
| Cutout | 803mmW x 493mmD |
| Capacity | 4 zones Front left: 230 x 210 mm, 2100W - boost 3700W Rear left: 230 x 210 mm, 2100W - boost 3700W Rear right: 230 x 210 mm, 2100W - boost 3700W Front right: 230 x 210 mm, 2100W - boost 3700W Multizone left: 460 x 210 mm, boost 3700W Multizone right right: 460 x 210 mm, boost 3700W |
| Functions | Keep warm function Simmering function Low temperature cooking function Pause option |
| Timer | End of cooking acoustic alarm Residual time indicator Minute minder |
| Ignition | Automatic electronic |
| Controls | Slider control |
| Safety | Pan detection Automatic cut-off Residual heat indicator Control lock Child safety |
| Power | 220 - 240V 50/60Hz 32Amp Connection |
| Pan size | Automatic pan size recognition |
| Warranty | Five years parts and labour |

RANGEHOOD

| | |
|----------------------|---|
| Motor | 1 x 220W |
| Max Airflow | 700m ³ /hr (IEC 61591) |
| Noise rating | 51-72dBA (IEC 60704-2-13) |
| Speeds | Eight + Two intensive |
| Functions | Auto Vent |
| Features | 2 x liquid collectors |
| Supplied accessories | Flush cast-iron grid 1 x ceramic filter |
| Ducting Options | Duct to atmosphere / recirculate — 150mm diameter ducting required |

ID211125

HOB682D1

INTEGRATED INDUCTION COOKTOP

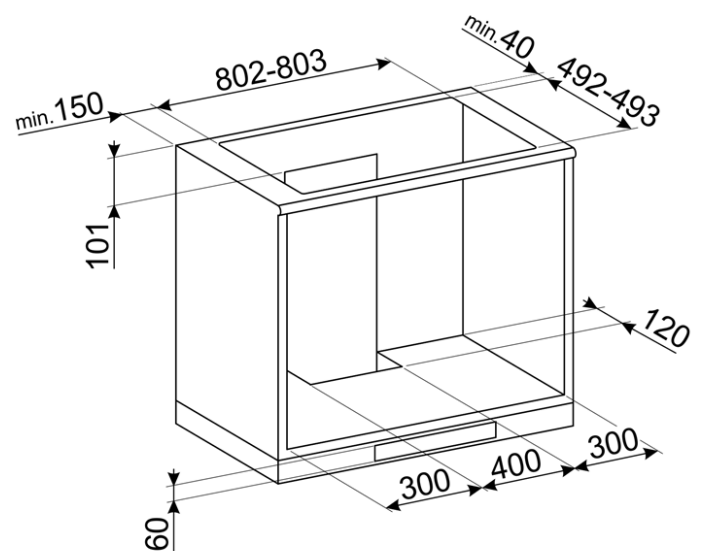
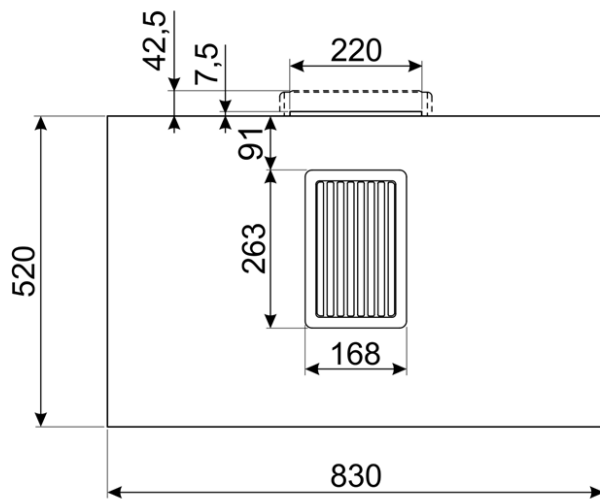
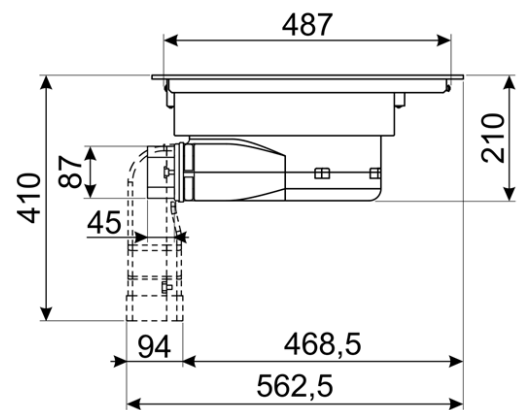
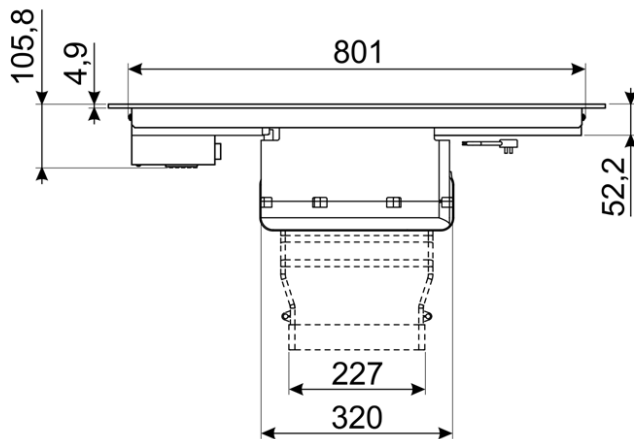

PLEASE NOTE: drawings are not to scale. They are to assist only.
WARNING: technical specifications and product sizes can be varied by the manufacturer without notice.
Cutouts for appliances should only be by physical product measurements. The above information is indicative only.