

# DWAFI6D15PO

## 60CM DIAMOND SERIES FULLY INTEGRATED PUSH TO OPEN DISHWASHER

**MADE IN ITALY**  
Since 1948

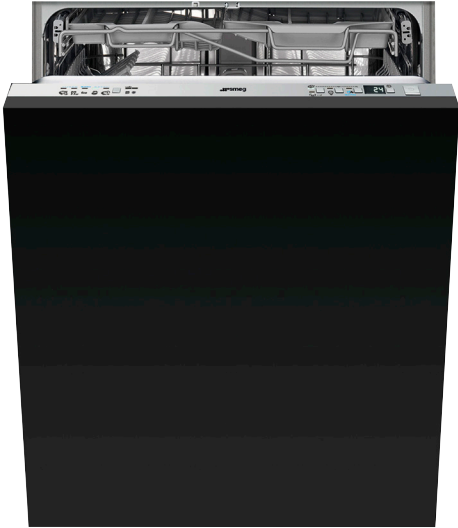

### PLANETARY WASH SYSTEM

Smeg's world-first planetary wash system features a single wash arm which rotates around two axes, significantly increasing wash pattern density and cleanliness. Angled jets reach in between every piece in the dishwasher for the most thorough and energy-efficient wash to date.

### PUSH TO OPEN

With a variable temperature control up to 80°C and sleek push-to-open operation, warming drawers add functionality as well as an aesthetically pleasing uninterrupted line.

### FLEXI DUO CUTLERY TRAY

The upper cutlery basket folds and slides ingeniously to free space in the basket below for tall items such as stemmed glassware while still providing space in the upper basket for cutlery and utensils.

### ACTIVE ACQUASTOP

By electronically determining when and how much water to let into the dishwasher, Smeg's Active Acquastop automatically controls the water feed at the tap. This ensures there is no pressure in the inlet hose, eliminating the risk of bursting.

### 5 STAGE FILTRATION SYSTEM

The ultimate dishwasher filtration system maintains a high quality wash by trapping food, thus preventing it from re-entering the wash system.

### SMARTDRY (ENERSAVE)

Smeg's Enersave system opens the door slightly at the end of the wash program. This option allows the residual heat of the machine to dry the load, including hard-to-dry items naturally and thoroughly, without the consumption of additional energy.

### TALL TANK

Smeg's tall tank dishwashers offer large capacity and versatility. 35cm plates, platters, bowls and awkward shapes are easily accommodated with adjustable baskets and cutlery tray.

Dimensions	598mmW x 858–928mmH x 550mmD
Finish	Integrated
Total functions	5 + 5 Quick Programs
Capacity	15 Place settings
Warranty	Five years parts and labour

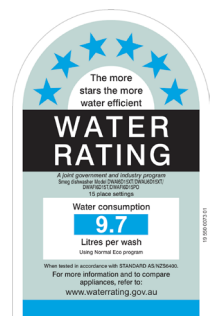
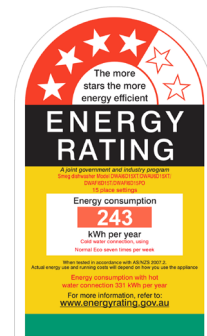
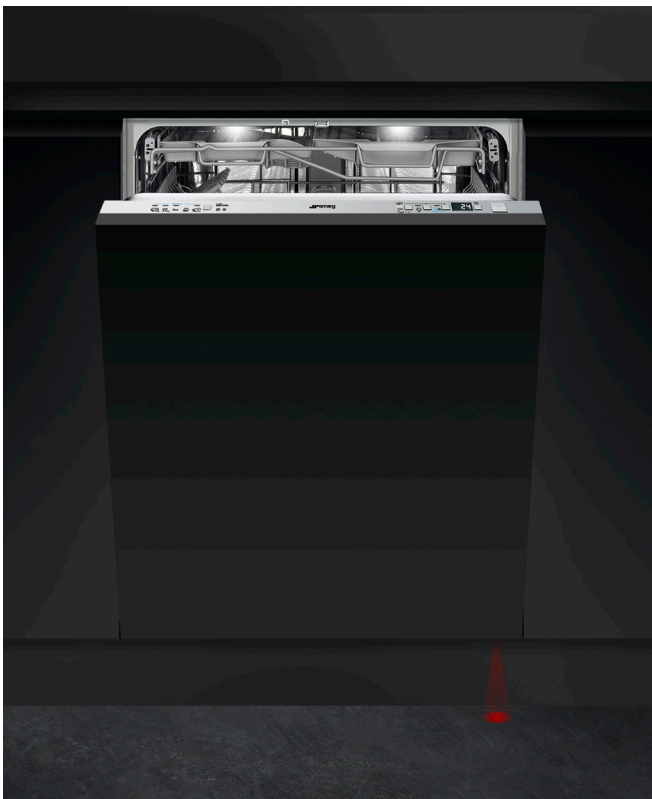

# DWAFI6D15PO

## 60CM DIAMOND SERIES FULLY INTEGRATED PUSH TO OPEN DISHWASHER

**MADE IN ITALY**  
Since 1948

### DISHWASHER FEATURES

Size	598mmW x 858-928mmH x 550mmD
Capacity	15 Place settings
Type	Fully-integrated
Finish	Integrated
Display	LED
Programs	5 + 5 Quick Programs
End of cycle indicator	ActiveLight
Baskets	3 Levels
Wash system	Planetary Wash System
Water softener	Yes – electronically adjustable
Temperatures	38°, 45°, 50°, 65°, 70°C
Features	Push to Open Internal LED lights Aquatest turbidity sensor Quicktime wash setting for each program ½ Load FlexiZone Fully adjustable baskets Self balancing hinges
Water connection	Hot or cold Water Connection (60°C Max)
Timer	Up to 24 hours, with automatic soak
Filtration	Stainless steel 5 stage filter
Drying	Natural condenser drying with SmartDry (Enersave)
Safety	Active Acquastop
Noise	42 dBA
Energy Usage	243 kWh/year
Energy Rating	4 Star
Water usage	9.7 Litres
Water Rating	6 Star
Power	230-240V, 50/60 Hz 1800W 10A
Warranty	Five years parts and labour

### DISHWASHER PROGRAMS



### DISHWASHER FUNCTIONS

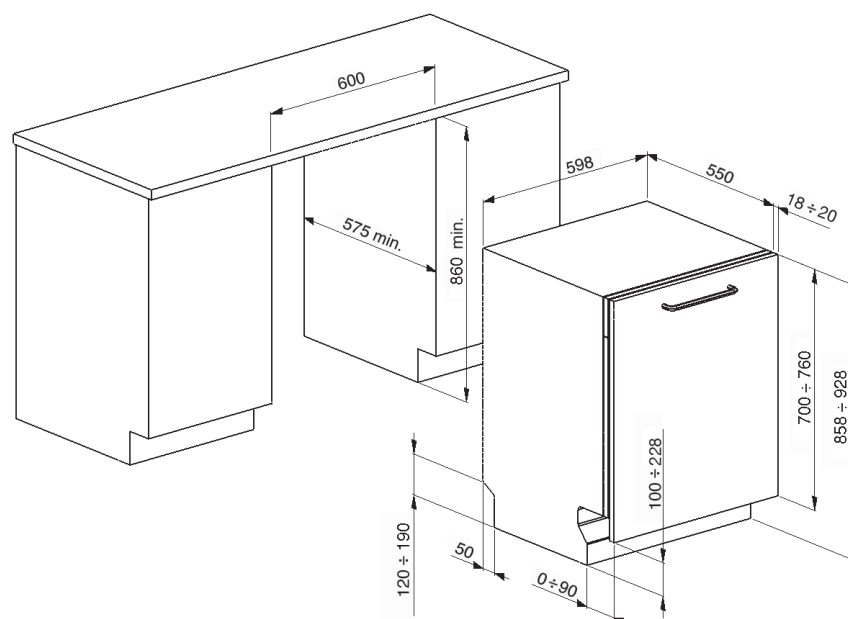

**DWAFI6D15PO**  
60CM DIAMOND SERIES FULLY INTEGRATED  
PUSH TO OPEN DISHWASHER

**MADE IN ITALY**  
Since 1948



Dimensions	598mmW x 858-928mmH x 550mmD
Power	230-240V, 50/60 Hz 1800W 10A
Warranty	Five years parts and labour

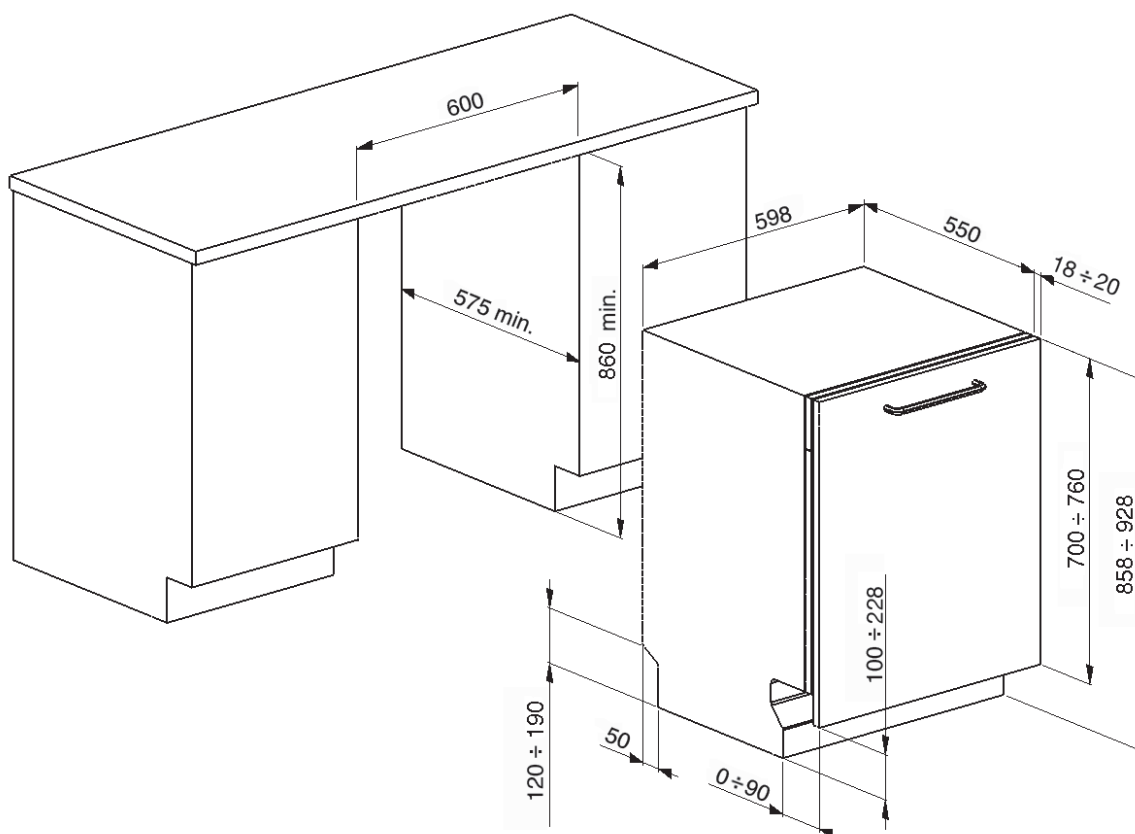

PLEASE NOTE: drawings are not to scale. They are to assist only.

WARNING: technical specifications and product sizes can be varied by the manufacturer without notice.

Cutouts for appliances should only be by physical product measurements. The above information is indicative only.