

## DOSPA6925X

### SMEG STAINLESS STEEL VICTORIA DOUBLE OVEN



EAN 8017709224684

|                      |   |
|----------------------|---|
| Finish               | Stainless steel   |
| Total functions      | Main oven 14<br>Aux oven 4  |
| Display              | Large LCD   |
| Capacity             | Main oven 79 litres<br>Aux oven 41 litres   |
| Cooking levels       | Main oven 5<br>Aux oven 2   |
| Thermostat           | Main oven 30 - 280°C<br>Aux oven 50 - 270°C   |
| Installation         | Flush or wallmount  |
| Programmability      | Fully programmable  |
| Cleaning             | Smeg Ever Clean enamel, Pyrolytic / ECO Pyrolytic   |
| Lighting             | Main oven 1 x 40W halogen<br>Aux oven 1 40W halogen   |
| Supplied accessories | 2 x Chrome grill insert<br>3 x Chrome shelves<br>1 x 20mm enamelled baking tray<br>2 x 40mm enamelled baking tray<br>1 x Partial telescopic guides  |
| Optional accessories | PRTX - Pizza Stone<br>PPR2 - Gourmet Cooking Stone<br>PALPZ - Single-handle pizza paddle<br>SSDPLUS - Baking Dish<br>GT1P-1 - Partial telescopic guides<br>GT1T-1 - Total telescopic guides |
| Safety               | Cool Door technology, thermal protection system, child safety lock, controls lock   |
| Dimensions           | 597mmW x 884mmH x 567mmD  |
| Power                | 220-240V,<br>50/60Hz<br>25A   |
| Warranty             | Two years parts and labour  |



### THERMOSEAL

The seal of Smeg's quality, technical excellence and taste: succulent roasts, crisp pastry and impressive baking is achieved in Smeg's unique, perfectly controlled cooking environment. Thermoseal maintains the perfect atmospheric balance in the cavity for optimum cooking conditions.



### PYROLYTIC CLEANING

Smeg's pyrolytic cycle locks the door and heats the oven to around 500°C. This process carbonises any food residue or burnt-on grease to a small amount of ash, which can be simply wiped away with a damp cloth. Smeg also has Eco Pyro - the low energy option.



### SMARTSENSE

Smeg's SmartSense intuitive program selection is easy-to-read in the large LCD panel. Effortlessly select oven functions, temperature and time for cooking; enter the time you want your meal to be ready and your delay start is calculated for you; or cook 20 pre-programmed favourites at the flick of a button.



### EVER CLEAN ENAMEL

The superior quality of Smeg's patented Ever Clean enamel, which is highly durable and easy to clean, is the result of nearly 70 years of enameling expertise; ensuring long-life performance of every Smeg oven.



### COOL DOOR TECHNOLOGY

Smeg's Cool Door system is a combination of technologies which is driven by a 22 blade tangential fan and includes a heat exchange baffle system. It draws cool air up through the panes of heat-reflective glass in the door, making it safe to the touch even when the oven is at pyrolytic temperatures of around 500°C.

VICTORIA COLLECTION

FUNCTIONS (Main Oven):

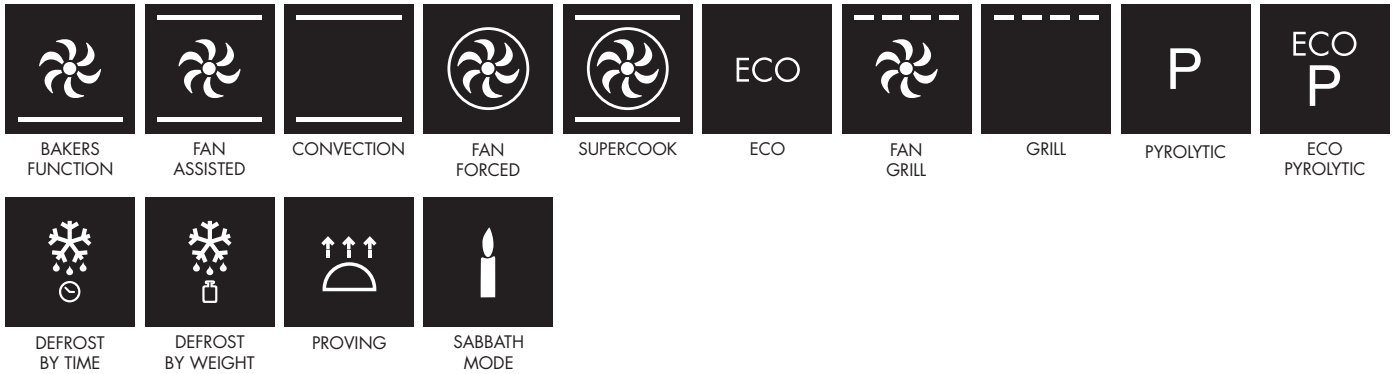

FUNCTIONS (Aux Oven):

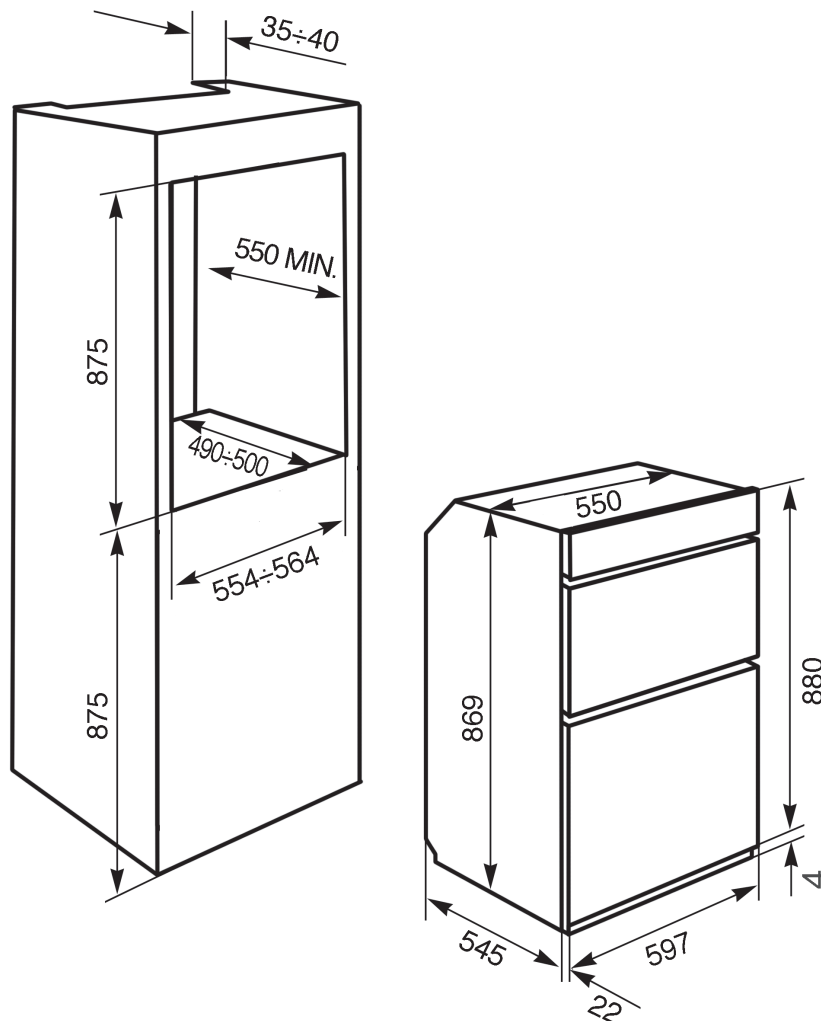

PLEASE NOTE: drawings are not to scale. They are to assist only.  
 WARNING: technical specifications and product sizes can be varied by the manufacturer without notice.  
 Cutouts for appliances should only be by physical product measurements. The above information is indicative only.