

CVIA118LS2

45CM LINEAR WINE CELLAR - LEFT-HAND HINGE

MADE IN ITALY
 Since 1948



Dimensions	596mmW x 448mmH x 554mmD
Finish	Silver Stopsol® glass
Display	LED Display with External touch control
Warranty	Five years parts and labour

Colours Available



CVIA118LS2
Silver
Left Hinge



CVIA118RS2
Silver
Right Hinge



CVIA118LN2
Black
Left Hinge



CVIA118RN2
Black
Right Hinge

EXTERNAL TEMPERATURE CONTROL

Smeg wine cellars feature a user-friendly touch-control display on the outside of the door glass, which allows access to change temperature, humidity and light without opening the door. This prevents changes in the internal temperature, reduces vibration and exposure to UV rays.

18 BOTTLE CAPACITY

Storage of up to 18 Bordeaux (750ml) bottles. Perfectly shaped housings provide ample storage for different shaped bottles. Champagne and magnums can be stored horizontally without risk of sliding.

PREMIUM OAK SHELVES

Telescopic sliding oak shelves allow for easy placement, storage and removal. The smooth movement prevents disturbance of wine sediment. Made in Italy, these racks are crafted from the same oak as traditional wine barrels.

UV RESISTANT GLASS

Thanks to Smeg's Eclipse black-glass technology, wine is perfectly shielded. The layered glass protects wine from damaging light and gives maximum transparency. Solar light and UV rays can alter a wine's structure, ruining its balance and flattening its scent.

VIBRATION PROTECTION

Smeg wine cellars are equipped with an ultra-quiet cooling system which keeps vibrations down to a minimum. Even the smallest vibrations can affect wine by lifting sediments. This causes different components to mix, altering the balance developed during the ageing period.



CVIA118LS2

45CM LINEAR WINE CELLAR - LEFT-HAND HINGE

MADE IN ITALY
Since 1948

WINE CELLAR FEATURES

Dimensions	596mmW x 448mmH x 554mmD
Finish	Silver Stopsol® glass
Display	LED Display with External touch control
Capacity	18 bottles (750ml)
Door	Push to open UV resistant Eclipse Black Glass Double glazed
Shelves	1 x fixed wooden shelves 2 x removable wooden shelves on telescopic guide rails
Thermostat	5-20°C
Installation	Built-in
Cooling	Fan-assisted
Air Filter	Active carbon filter
Lighting	LED internal light
Safety	Control lock Door open alarm
Power	220-240V, 50/60Hz 40W 0.4A Connection
Warranty	Five years parts and labour



SUPPLIED ACCESSORIES

Telescopic guide rails

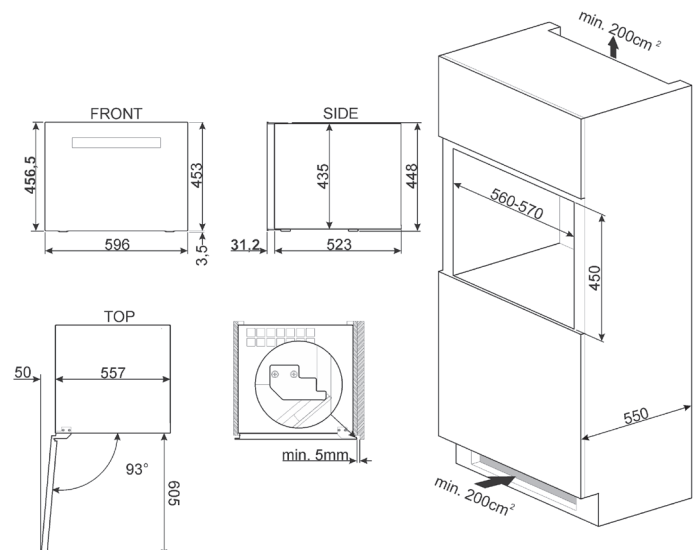

CVIA118LS2
45CM LINEAR WINE CELLAR - LEFT-HAND HINGE

MADE IN ITALY
Since 1948



Dimensions	596mmW x 448mmH x 554mmD
Power	220-240V, 50/60Hz 40W 0.4A Connection
Warranty	Five years parts and labour

