

CMVANILLA

smeg 52cm diameter island rangehood



<b>EAN</b>	9345025000934
<b>finish</b>	stainless steel/white patterned glass
<b>dimensions</b>	518mm diameter
<b>installation</b>	island
<b>motor</b>	1 x 340W
<b>air extraction</b>	recirculate to kitchen
<b>capacity</b>	540m <sup>3</sup> /hr (IEC 61591: p=0) 520m <sup>3</sup> /hr (IEC 61591: p=1)
<b>noise rating</b>	49-68 dBA (IEC 60704-3)
<b>illumination</b>	4 X 20W halogen globes
<b>speeds</b>	three, electronic touch control + intensive*
<b>power</b>	220-240V, 50Hz
<b>supplied</b>	1 x aluminium grease filters, 1 x charcoal filter, remote control
<b>optional</b>	charcoal filter, part # 133.0267.277

p = 0 → airflow direct out of motor housing  
p = 1 → airflow after 1m & 90° bend + 1m

\*INTENSIVE: the Intensive Speed function activates maximum air extraction for 10 minutes to meet the needs heavy-duty cooking, such as stir-fry.

#### ENERGY DIFFUSER

Reduces noise level by up to 3 dBA, and increases rangehood efficiency by 30%.

#### DELAYED SWITCH OFF

Motor will run at a low speed for approximately 10 minutes for complete elimination of odours. Switches off automatically.

#### KEY 24

Activates the motor to run at a low level for 24 hours for continuous air renewal.

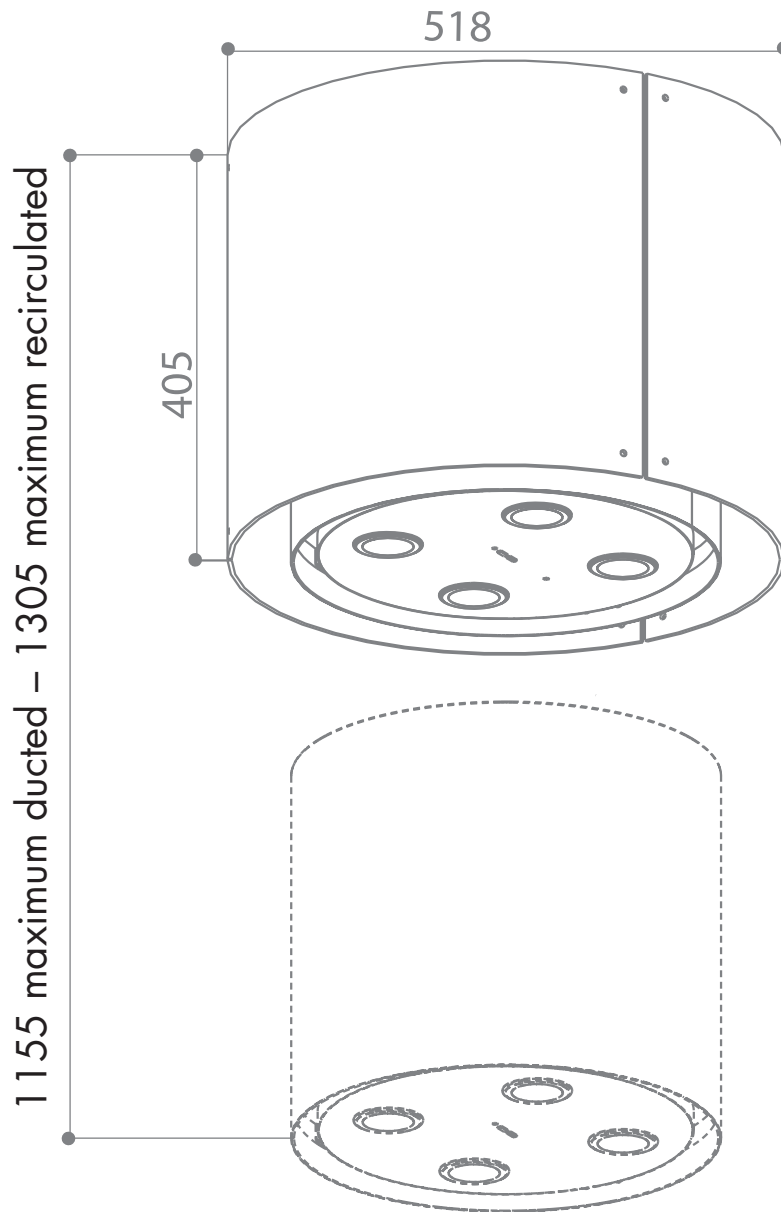

**PLEASE NOTE: drawings are not to scale. They are to assist only.**