

CMS6451X SMEG COFFEE MACHINE, CLASSIC DESIGN



EAN 8017709206277

Dimensions	595mmW x 455mmH x 381mmD
Finish	Fingerprint proof stainless steel Eclipse high visibility black glass
Display	LCD
Thermostat	3 x Adjustable temperatures
Pump Pressure	15 Bar
Coffee Bean Capacity	220g
Water tank capacity	1.8L
Installation	Built-in
Functions	Fully automatic coffee preparation Automatic cappuccino maker, with adjustable froth Ground coffee option Hot water function (tea or other hot drinks) Rinsing function
Programmability	5 Preset coffee strengths: single or double shot extra light, light, medium, strong, extra strong 3 Variable coffee lengths: short/espresso, medium, long
Cleaning	Automatic descaling
Lighting	2 x LED
Supplied accessories	1 x Removable milk jug
Safety	Thermal protection
Power	220-240V, 50/60 Hz 1350W 10A connection
Warranty	Two years parts and labour

PROFESSIONAL RESULTS

The Smeg built-in compact coffee machine, completely automatic and very simple to use, is perfect for preparing delicious coffee and cappuccino, just like the hot drinks that you would enjoy in a coffee shop, yet from the comfort of your own home.

EASE OF USE

The new CMS6451X from Smeg has an LCD display that clearly and intuitively supplies multilingual information. Coffee can be prepared using either beans or ground coffee and it is possible to prepare one or two cups at the same time. With the steam function, milk or cappuccino can be prepared with a generous topping of foam, and there is a hot water function for tea and other hot drinks. The useful rinsing function can be employed to clean the machine after use or to heat the cups before pouring a coffee, a technique used by connoisseurs to exalt the aroma and taste of the coffee.

VERSATILITY

The Smeg coffee machine is extremely versatile, allowing you to prepare different strength coffees (from extra-mild, to mild, medium, strong, or extra-strong) and quantities (from espresso, to medium and long). Even the temperature of the coffee can be regulated on three different levels so that you can customise it completely to your personal tastes.

MAINTENANCE

The CMS6451X automatically carries out a rinsing and a descaling operation every time it is switched on or off. It can be easily programmed to switch itself on – meaning that the machine will be ready, for example, in the morning for you to immediately prepare a fresh coffee as soon as you get up, whilst the stand-by function allows you to save energy.

It includes a removable water container, a container for coffee beans, a separate compartment for ground coffee and a drawer for the grinds (used coffee). It also has two lights, telescopic guide rails for ergonomic access to the coffee container and can be adjusted for different height cups. A water connection is not necessary for a Smeg coffee machine meaning that it is possible to connect the coffee machine anywhere in the kitchen

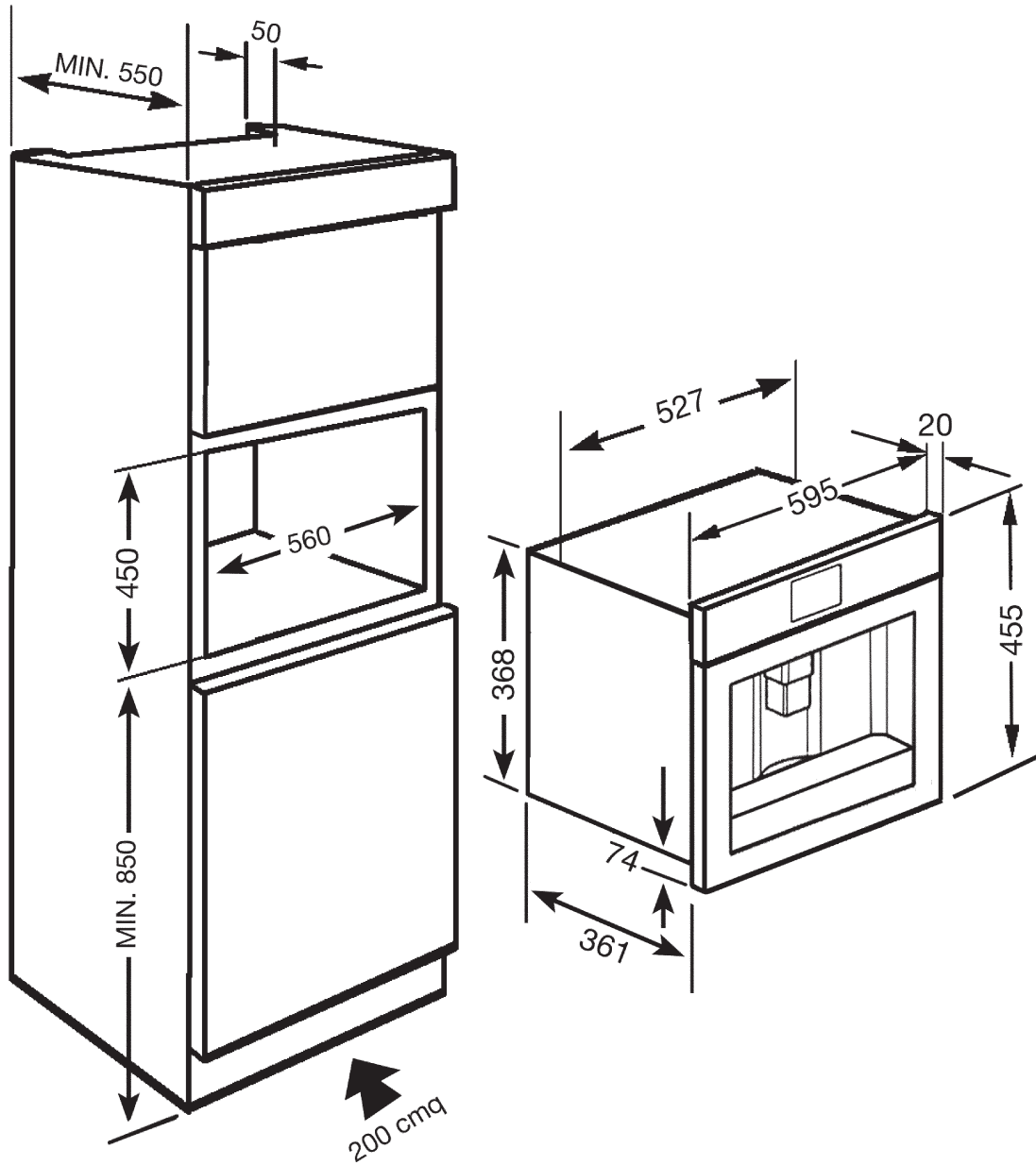

PLEASE NOTE: drawings are not to scale. They are to assist only.

WARNING: technical specifications and product sizes can be varied by the manufacturer without notice.

Cutouts for appliances should only be by physical product measurements. The above information is indicative only.