

# CMS4101B

## 60CM LINEAR BUILT-IN COFFEE MACHINE

**MADE IN ITALY**  
Since 1948



Dimensions	595mmW x 455mmH x 381mmD
Finish	White Stopsol® glass
Display	Multilanguage LCD
Warranty	Five years parts and labour

### 15 BAR PRESSURE

This coffee maker uses a 15-bar pump pressure, which concentrates beans at an optimal level to give your brews a rich taste and a perfect crema.

### CHOICE OF COFFEE STRENGTH

The Smeg coffee machine is extremely versatile, allowing you to prepare different strength coffees (from extra-mild, to mild, medium, strong, or extra-strong) and quantities (from espresso, to medium and long). Customise it completely to suit your personal tastes.

### CHOICE OF COFFEE LENGTH

It is finally possible to enjoy the Italian café experience in the comfort of your own home: the aroma of real espresso, the taste of a creamy cappuccino, or a delicious latte, all prepared in the convenience of your own kitchen.

### ADJUSTABLE TEMPERATURE

What sets the Smeg coffee machine apart is the new Thermoblock heating system, which readies the machine for use more quickly and provides precise control over the water temperature to provide coffee, steam or hot water for the perfect cup.

### AUTOMATIC STEAM FUNCTION

The Smeg built-in coffee machine, completely automatic and simple to use, is perfect for preparing delicious coffee and cappuccino, just like the hot drinks that you would enjoy in a coffee shop, but from the comfort of your own home.

### Colours Available



Black  
CMS4101N



White  
CMS4101B



Silver  
CMS4101S



# CMS4101B

## 60CM LINEAR BUILT-IN COFFEE MACHINE

MADE IN ITALY  
Since 1948

### COFFEE MACHINE FEATURES

Dimensions	595mmW x 455mmH x 381mmD
Finish	White Stopsol® glass
Display	Multilanguage LCD
Thermostat	3 x adjustable temperatures
Pump Pressure	15 bar
Coffee Bean Capacity	220 grams
Water tank capacity	1.8 litres
Installation	Flush fitment, built-in
Functions	fully automatic coffee preparation (for regular or double coffee) steam function (cappuccino, latte) hot water function (tea or other hot drinks) rinsing function
Programmability	5 coffee strength levels extra light light medium strong extra strong Water quantity: short/espresso medium long
Cleaning	Automatic rinsing and descaling operation
Lighting	2 x LED lights
Safety	Thermal protection
Power	1350W, 10A, 3-pin plug
Warranty	Five years parts and labour

### SUPPLIED ACCESSORIES

- 1 x Removable milk jug
- 1 x frothing nozzle for cappuccino

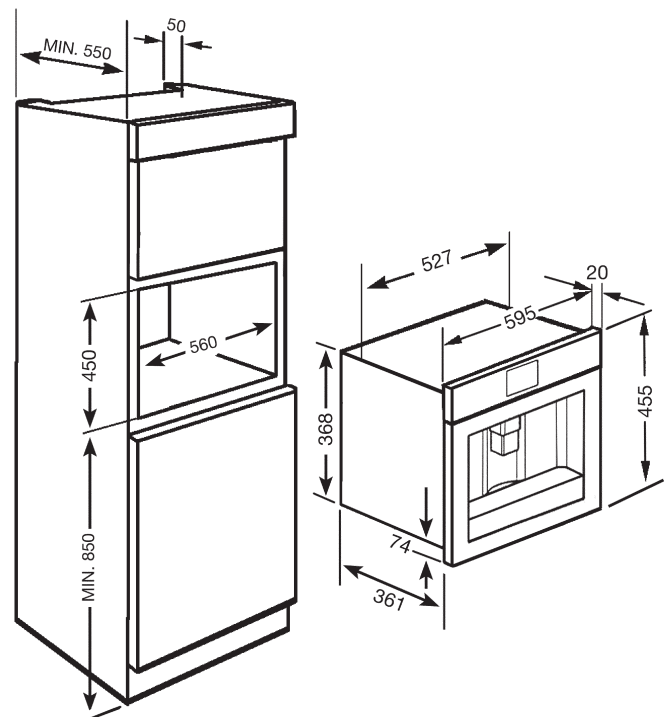

**CMS4101B**  
60CM LINEAR BUILT-IN COFFEE MACHINE

**MADE IN ITALY**  
Since 1948



Dimensions	595mmW x 455mmH x 381mmD
Power	1350W 10A, 3-pin plug
Warranty	Five years parts and labour

